

“Superfluous”:
The Stories of Einstein’s Special Relativity

Draft

Raymond Brock

January 16, 2023

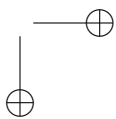
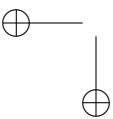
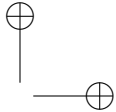

Contents

Contents	6
1 The Greeks	7
1.1 A Little Bit of The Presocratic Greeks	10
1.1.1 ACT I: Is Nature Made From Stuff Governed By Rules?	11
1.1.1.1 The World Before Thales & Co.	14
1.1.1.2 Thales' Science and His Successors	15
1.1.2 ACT II: Pythagoreans in the West	17
1.1.2.1 The Most Durable Discovery in History	18
1.1.3 ACT III: The Eleatics in the West	24
1.1.3.1 The Riddler	25
1.1.3.2 Nothing Gets Done: The Parmenides Problem	26
1.1.4 ACT IV: Antidotes to Parmenides?	28
1.1.4.1 Empedocles and Anaxagoras	29
1.1.4.2 Atoms	30
1.1.5 What's Important For Our Project	32
1.2 More of the Presocratic Greeks' Stories	33
1.2.1 Tweeting With Heraclitus	33
1.2.2 Modern Day Pythagoreans	35
<i>MPy</i> ₁ Mathematics describes the universe	36
<i>MPy</i> ₂ There are special numbers	38
<i>MPy</i> ₃ Integers matter	38
<i>MPy</i> ₄ Patterns and symmetries play important roles . .	39
<i>MPy</i> ₅ Approximation is appropriate	39
1.2.2.1 Unreasonable?	40
1.2.3 Zeno and His Paradoxes	41
2 Plato and Aristotle	43
2.1 Act V A Little Bit of Plato	45
2.1.1 What Is True Knowledge?	47
2.1.2 The Forms	49
2.1.3 The Republic	50
2.1.4 Mathematics For Plato from Republic	52

2.1.4.1	The Soul	54
2.1.5	Timaeus	55
2.1.6	Platonic Legacy	57
2.2	Act VI A Little Bit of Aristotle	58
2.2.1	Aristotle and What's Real and What's Knowledge?	60
2.2.2	Change and Cause	60
2.2.3	Aristotle's Physics	63
2.2.4	Summary of Aristotle and Locomotion	66
2.3	Plato and Aristotle, Today	66
2.3.1	Modern Day Platonists	66
2.3.2	The Platonic Process in Physics	67
2.3.3	The Platonic Reality in Physics	71
2.3.3.1	Their Own Forms	71
2.3.3.2	Are Wavefunctions BW Or RW Or Not Real At All?	72
2.3.4	Aristotle's Legacy in Physics and Engineering	73
2.3.4.1	Greatest gift	75
2.3.4.2	Deduction and Induction	75
2.3.4.3	Your phone	78
2.3.4.4	The Punch Line:	81
3	Eudoxus and Greek Astronomy	85
3.1	A Little Bit of Eudoxus	89
3.2	A Little Bit of Greek Astronomy	92
3.2.1	What We Know Now	92
3.2.2	Let's Set The Record Straight	94
3.2.3	Greek Astronomy, Presocratics	98
3.2.4	Classical Greek Astronomy	102
3.2.4.1	Plato's Two Models	102
3.2.5	Eudoxus' Model	107
3.2.6	Aristotle's Model	109
3.2.6.1	Properties of the Earth, Aristotle-style	109
Shape of the Earth	109	
Motion of the Earth	112	
Stellar Parallax	113	
3.2.6.2	The Physics of Aristotle's Cosmology	114
3.2.7	Hellenistic Astronomy	117
3.2.7.1	A Moving Earth	117
3.2.7.2	Casting Aside Aristotle and Eudoxus	120
3.2.7.3	The Greatest Astronomer	122
3.3	Greek Astronomy, Today	124
3.3.0.1	Modern Day Platonists	124
15	Michelson	125
15.1	A Little Bit of Michelson	126

15.1.1	The Navy	127
15.1.2	Light	129
15.1.2.1	It's Really Fast	129
15.1.3	Where Is the Ether?	130
15.1.3.1	Moving Through The Ether	131
15.1.4	The Michelson Interferometer	132
15.1.4.1	With The Phone Guy's Help	135
15.1.5	Getting Serious: Michelson Meets Morley	138
15.1.5.1	Cleveland	138
15.1.6	The "Michelson Morley Experiment"	141
15.1.7	Michelson and Chicago	144
15.1.7.1	A Meter	144
15.1.7.2	University of Chicago	145
15.2	More of the Michelson Story	148
15.2.1	His Interferometer	148
15.2.1.1	Spectroscopy and Materials Science	148
15.2.2	Astronomy	149
15.2.2.1	The Limits of Telescopes, or Eyes	149
15.2.3	Actual Telescopes	150
15.2.4	Michelson's Star Project	152
15.2.4.1	Optical Interferometry	152
15.2.4.2	One Star's Width	153
15.2.4.3	Betelgeuse	155
15.2.5	Interferometers in the Modern Age	156
15.2.5.1	Radio Astronomy	158
15.2.5.2	Gravitational Waves	160
15.2.6	The Speed of Light	161
15.2.6.1	Modern Measurements, Beyond the Michelson Ap- proach	162
15.2.6.2	Lasers In The 1960s	164
15.2.6.3	The End	164
Appendices		169
A Greeks Technical Appendix		169
A.1	Zeno's Paradox	169
A.2	Proof of Pythagoras' Theorem	169
A.3	Socrates' Geometrical Problem	169
B Plato–Aristotle Technical Appendix		171
B.1	Digital Gates	171
C Greek Astronomy Technical Appendix		173
C.1	The Greek Sky	173

C.1.0.1 Observation #1: stars' motion 173
C.1.0.2 Observation #2: planets' motions 173
C.1.0.3 Observation #3: that fuzzy stripe 176
C.1.0.4 Observation 4: The Moon 178
C.1.0.5 Observation 5: The Sun 179

Sources **181**

Chapter 15

The Most Important Zero Ever: Albert Michelson

“While it is never safe to affirm that the future of Physical Science has no marvels in store even more astonishing than those of the past, it seems probable that most of the grand underlying principles have been firmly established and that further advances are to be sought chiefly in the rigorous application of these principles to all the phenomena which come under our notice. It is here that the science of measurement shows its importance — where quantitative work is more to be desired than qualitative work.”

- Michelson, *Convocation Address at the Dedication of the Ryerson Physical Laboratory at the University of Chicago, 1894*

Our story now takes a surprising and even unwelcome turn. Our last experimental stop before we get to Einstein. Up until now, our themes of MOTION BY THE EARTH, MOTION ON THE EARTH, MOTION IN THE HEAVENS, and LIGHT have been separate subjects with intermingling MOTION story lines and a completely different path for LIGHT.

We'll now consider one of the most important experiments in the last two centuries, and certainly the most important measurement ever of **zero** ever. It starts in the Wild West of gold and silver mining—literally, the Wild West—and passes through Stockholm and the Nobel Prize. Let's talk about one of the more interesting physicists of all. Albert Michelson, a complicated person notoriously stern and difficult (although he was an accomplished artist, musician, and tennis and billiards player). He once had an argument about an experiment with

a colleague in a hotel lobby that drew a crowd, maybe because they were loud and maybe because Michelson was still in his pajamas. He won the Nobel Prize in 1907, not for his most famous measurement of zero, but for his exquisitely precise instruments and the collection of scientific measurements that he made with them. He never accepted the results of that ground-breaking experiment.

15.1 A Little Bit of Michelson

Faced with a difficult situation, he did what any 16 year old would do: he boarded the brand new Transcontinental Railroad at Oakland Land Wharf in San Francisco and went to Washington, D.C. to see the President. Albert was nothing, if not persistent.

Albert Michelson was born in 1852 in Poland to Rosalie and Samuel Michelson. Life for Jews in Prussia was untenable and so this small family decided to emigrate in a big way, following Samuel's sister and brother-in-law to the California Gold Rush. With two babies in tow, Samuel and Rosalie left from Hamburg for New York, and then San Francisco. Not to chase gold, but to sell dry goods to the miners. As a merchant, that's what Samuel knew best.

Sailing around Cape Horn or traveling across the country in covered wagons must have seemed too tame for this adventurous couple. From New York they boarded a steamer for Panama, then by canoe, mule train, and a brand new railway, made their way across the Isthmus of Panama to a clipper ship and then on to San Francisco. It was a harrowing journey during which they lacked water, fought exotic insects, faced danger from outlaws, and avoided the desperately sick natives who were all around them. It made an impression on three year old Albert that he never forgot. In retrospect, covered wagons must have seemed like a better alternative.

The last leg of their journey was by stagecoach from the city to Murphy's Camp in the foothills of California's Sierra Nevada mountains. After more than a year of dangerous travel, they settled alongside Samuel's brother-in-law and set up shop with the goods needed by any respectable prospector.

Tens of millions of dollars in gold was shipped from Murphy's Camp and that kind of activity came equipped with hard edges. The town resembled a bad cowboy movie: full of drunks, violence, and public hangings—and lots of cash. It thrived in its own way until it all burned to the ground in 1859 in less than an hour.

The town and the Michelsons rebuilt but by the time Albert was 12 years old in 1864, Rosalie decided that he needed a more formal education than available in Murphy's. She had tutored him, even insisting on violin lessons. But Albert was sent with his



Figure 15.1: Michelson Store, Main Street, Murphys Camp (Library of Congress)

aunt and uncle to San Francisco for high school where he so impressed the principal, that he was taken into his home and given special access to the school's science lab... and boxing lessons.

By this time Murphy's gold had dried up and the family moved to Virginia City, Nevada... where silver was all the rage and their new boom-town swelled to 30,000 inhabitants. The family moved into a large house over Samuel's new store where the business flourished. A father-son enterprise was a possibility, but by this time Albert needed a different path. A scientific one.

15.1.1 The Navy

Today, in order to enter a U.S. military academy, an 18 year old requires a nomination by a state or federal elected representative. It's a highly competitive process requiring superior academics and typically, an athletic background. Albert's growing interest in science had led to a favorably received paper on optics and he wanted to pursue this subject. But how?

The U.S. Naval Academy at Annapolis, Maryland was then only 20 years old when Albert graduated from high school in San Francisco and Samuel learned that Nevada's Congressman Thomas Fitch was accepting nominations for boys to the Academy. Albert applied, took the exams and tied with two other applicants for first place. Fitch chose one of the other boys, who immediately failed prompting Fitch to write to President Grant on Albert's behalf. In what was to become a characteristic Albert-move, at the age when today's U.S. kids are just getting their learner's permits, he took matters into his own hands and did what his family

did: he got on the road. Hence, that solo teenage train ride across the rough North American continent.

When he arrived in Washington, D.C. he presented himself at the White House, and made his case to President Grant personally. At that time the President was allotted 10 at-large appointments (now the Vice President can nominate five) and Grant had used up that total. Not to be outdone, Albert then took himself to Annapolis and sought an audience with the Commandant where he was examined, did well, but told that there were no openings.

As Albert's daughter described later (?) (Dorothy Michelson Livingston wrote the definitive (technically accurate and moving) biography of her father.), he was literally at Union Station boarding the train to return to San Francisco when a messenger from the President intercepted him to say the the President had decided to appoint 11 midshipmen that year (and later two more, for a total of 13). Michelson always joked that he was probably illegally a student at the Naval Academy. But it worked out. In 1869 at the age of 17, Albert joined the Navy.

Albert was a popular and successful midshipman, not above the occasional fight or prank. He graduated in 1873 at or near the top in experimental and mathematical subjects—at the top in optics... and near the bottom in seamanship. He did his two-year obligatory training at sea off the coast of South America and the Caribbean in a combined steam-sailing ship, ending his sailing obligation in Norfolk as an Ensign. He decided to stay in the Navy and in 1875 was assigned physics instructor duties at the Academy under Lieutenant Commander William Sampson, the head of the Department of Natural and Experimental Philosophy who was to become a friend as well as mentor. Mrs. Sampson's niece recently returned from finishing school in Paris and Margaret Heminway was introduced to him at a family event. She was the daughter of a wealthy and powerful lawyer and investor in New York City. In spite of their age, religious, and class differences, Albert and Margaret were married in 1877—a marriage “up” for Albert into a rarified atmosphere as compared to his immigrant upbringings. Albert and Margaret welcomed their first son, Albert, in 1878.

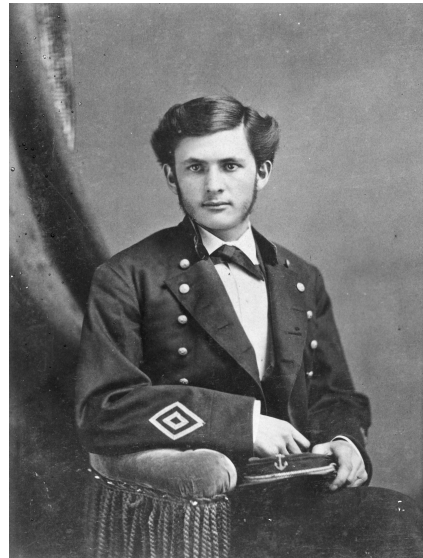

Figure 15.2: Albert Michelson as a cadet-officer. (AIP)

15.1.2 Light

One of Albert's first tasks as an instructor was to create demonstrations for the midshipmen in their physics classes and he chose to take on a relatively new method for measuring the speed of light, now an experiment done by physics students in hallways around the world. Except he made it better and found a calling.

15.1.2.1 It's Really Fast

In Chapter ?? we enumerated the many ways that the speed of light was determined prior to Michelson's time. Recall that it was Fizeau who did it best in 1848 by chopping the light up with a rotating mirror and capturing its return as the mirror rotated in the meantime.

This was the technique that Michelson adopted for his midshipmen students and by 1878 he had a handful of ideas to better engineer the device. He lengthened the path length to 11 meters, he greatly improved the various focussing lenses required for the beams, swapped Foucault's concave far mirror for a finely ground plane mirror, and he delicately engineered the rotating mirror assembly by driving it with a regulated, hand-operated bellows to a constant speed of 130 turns per second. With this first measurement, he obtained $c = 300,140,000$ m/s with an uncertainty of about 0.2%. It cost him \$10 in 1878 dollars.

In the same year that he and Margaret had a second child, he obsessed about getting a new apparatus to work. With a lot of support from the Academy (he was, after all still in the Navy but with this unusual research assignment), \$2000 (worth more than \$50,000 today) from his father-in-law, and space at Annapolis along the waterfront, he was able to retain services from first-class instrument and optical manufacturers. Meanwhile, Congress had turned down a request of support and awarded \$5000 to Simon Newcomb, a distinguished astronomer who actually suggested improvements in the young man's plans and supported him publicly. His new path-length was to be 609 meters and his rotating mirror assembly was a delicately controlled 128 revolutions per second (he'd already destroyed an assembly at high speed when its balance was not perfect). He devised a tuning-fork with a small mirror attached. When it vibrated at its precise frequency, and the rotating mirror was in synch, stable images of the rotating mirror would show in the tuning fork's mirror. The time of day was regulated, as the heat would change dimensions of the apparatus. His result was $c = 299,910,000 \pm 50,000$ m/s, or a precision of $\pm 0.017\%$.

Measurement of the speed of light became his life-long passion and he was working on an audacious experiment in the hills of southern California when he died in 1931. His previous 1924 measurement of $c = 299,796,000 \pm 0.001\%$ m/s stood for three decades as most precise.

May 14, 1879, in the Virginia City Evening Chronicle:

"THE VELOCITY OF LIGHT A YOUNG COMSTOCKER'S CONTRIBUTION TO THE WORLD OF SCIENCE

"Ensign A. A. Michelson, a son of S. Michelson, the dry goods merchant of this city, has aroused the attention of the scientific minds of the country by his remarkable discoveries in measuring the velocity of light." The New York Times says: 'It would seem that the scientific world of America is destined to be adorned with a new and brilliant name. Ensign A. A. Michelson, a graduate of the Annapolis Naval Academy, and not yet 27 years of age, has distinguished himself by studies in the science of optics which promise the discovery of a method for measuring the velocity of light with almost as much accuracy as the velocity of an ordinary projectile...'"

Albert didn't want to go back to sea, which would have been his next Navy assignment. He was partially spared another sea voyage when Newcomb had enough influence to "borrow" Michelson from the Navy to work in his laboratory in Washington D.C. . . . where his job was to make his friendly competitor's Congressionally funded experiment work.

That probably wasn't ideal. He was fully aware that his engineering degree (until recently the service academies offered only engineering) would not qualify him for a university faculty position, but no institution in the United States offered a doctorate in physics.¹

Again, not shy, he requested and received a leave of absence from the Navy in order to pursue a Ph.D. and secured a position at Humbolt University in Berlin to study under and work with Helmholtz, whom we learned about in Chapter ???. Off the four of them went to Berlin, Margaret, two children, and Albert.

Helmholtz was an expert in optics, having revolutionized ophthalmology with his invention of the ophthalmoscope and was extraordinarily multidimensional. His mathematical codification of the conservation of energy (Chapter ???), development of the science of fluid dynamics, studies in acoustics, and both mathematical and experimental contributions to electromagnetism all marked his name in textbooks. . . in multiple fields. Not bad for a medical doctor.

Michelson had something on his mind that had come to him during their first stop in Paris and he went to Berlin with a research target in his mind: the ether.

15.1.3 Where Is the Ether?

As we saw in Chapter ??? it was Thomas Young who upon determining that light must be a wave, then postulated that there needed to be a substance "that waves." A very definition, if you will, of what light must be: the undulations of a substance, that ether. As preposterous is the properties of the ether are, we saw in Chapter ???

¹John's Hopkins University in Baltimore was about to offer Ph.D. degrees.

that nobody questioned it and huge experimental and theoretical efforts were expended in describing it and searching for evidence of it.

Sir Oliver Lodge was passionate (and relentless) on the subject, even after it was ultimately clear that he was wrong. He spoke for almost all of the now exhausted physics community:

“... it is absurd to imagine one piece of matter acting mechanically on another at a distance, whether that distance be large or small, without some intervening mechanism or connecting link...”

So in addition to the chaos in the theory camp, there was a corresponding chaotic situation among experiments going back many decades: some results demanded that the ether was stationary and that the Earth (somehow) moved through it and some experiments demanded that the ether was dragged along—wholly or partially—by the orbiting Earth. Chaos in both theory and experiment, an imperfect situation.

The ether’s job description included two assignments, solving two problems: First, it could function as Newton’s absolutely at-rest structure anchoring and even defining space and it second, it supported light’s wave propagation as convincingly suggested by Maxwell.

Always imaginative, Maxwell wondered about exactly that and during the last year of his life—the year before Michelson went to Europe—he suggested that it might be possible to measure the speed of the Earth relative to the fixed ether—which would appear on the Earth to be the ether passing by it... the “ether wind.” However, he worked out that the experimental accuracy of his scheme was depressingly impossible: it must distinguish speeds relative to the ether of about 0.0000000001%.

Michelson must have heard of Maxwell’s idea around the time that he was headed to Berlin and what was an impossibility to Maxwell, was a challenge to him. After all, precision optics seemed to be his game.

15.1.3.1 Moving Through The Ether

What was Maxwell’s idea? A naval analogy that Michelson later described to his children gives a good feeling for his plan. Let’s look at Figure Box [15.3](#) on page [133](#). After you’ve read the material in that Box, return to this point  and continue reading.

Now suppose we make the following substitutions in our nautical race:

- instead of boats→ we’ll use light beams;
- instead of the bank→ we’ll imagine the Earth; and
- instead of a river→ we’ll imagine an ether “current” passing by it, which is the same thing as being in the ether’s position and watching the Earth move through it the other direction.

15.1.4 The Michelson Interferometer

The instrument Michelson invented and spent a decade of his life perfecting is called the *Michelson Interferometer* and it's a standard tool in today's optics laboratories, industrial manufacturing, telecommunications, and even in astronomy.

Remember our discussion of Thomas Young's experiment with light where he demonstrated that light aimed at two holes or slits caused an interference pattern to emerge on a far screen which can only happen if light is a wave. When two waves go up or down together, they add and if they are exactly out of phase, one with the other, they subtract to zero. No wave. Dark. It's the principle behind your noise-cancelling headphones if those waves are sound waves.

Sometimes the waves interfere between total cancellation and total addition and the result is a new wave that can have a funny-looking shape.

FIGURE BOX 15.3

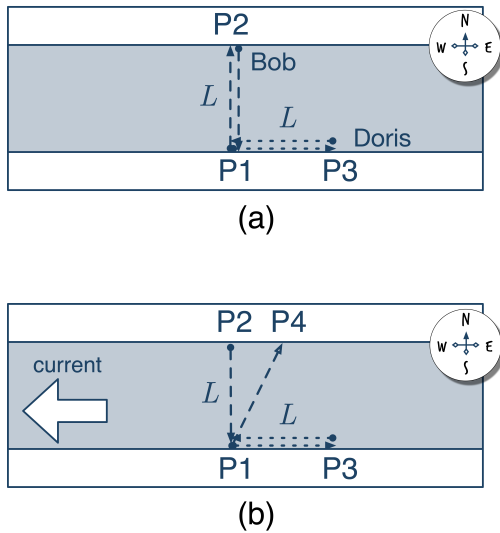

As shown on the left in Figure 15.3 (a), suppose Bob and Doris are to race in a river which has a width, L . They each plan to pilot their identical motor boats the same distances starting at the same point on the south shore (P1) and ending up back at that same location. Bob goes across the river north to the opposite shore (P2), and then returns south to P1. Doris pilots her boat a distance L to the east to P3 and then back to P1. In this race, the river is still—no current. Who wins if both boats can move through the water at the same speed?

Obviously, since they're both traveling at the same speed over the same distance

and if the water is perfectly calm, their round trip race would result in a tie. That's too easy.

Now suppose that the river has a strong current from east to west, as suggested in Figure 15.3 (b). Same boats, same relative speeds through the water, and the same trips, north then south for Bob and east and return west for Doris. Both travel to the same points as before, relative to the shore. Who wins now?

Since the river is flowing to the west, Doris has to fight the current to go the required distance to the east, but on her return, the current helps. Meanwhile, in order to get directly across the river, Bob has to aim to the east of his intended point so that the current pulls him back to the north shore directly opposite his starting position. Coming back, he must do the same sort of maneuver.

Who wins? Bob or Doris?

It turns out that the round trip across the river and back will be quicker than the trip to the right and to the left. (See Appendix ?? for the calculation.) So Bob wins.

Now go back to page [131](#) and pick up where you left off.

Light has wavelengths that are around 500 nanometers. That's 0.000000500 meters (for comparison, sound in a dry room at normal temperature, say Middle C, has a wavelength of about 4 feet.) That means that detecting a small difference between two light waves by separately comparing them side by side would have been impossibly difficult, but unraveling their *interference* is much easier to observe. So if an experimenter has a device that can measure the interference of two waves, then

they know that the waves arrived out of, or in, phase. If out, then one of them led and the other followed.

Let's imagine a slightly different analogy where water is not involved. Suppose we have two marchers, side by side. Gladys on the left walks beside Clyde on the right and they're both the same height and practice marching so thoroughly that when they walk beside one another, they are in phase: when Gladys's right foot goes down, so does Clyde's. Every stride is the same.

Let's suppose that they enter an school stadium side by side and when they reach the oval running track they separate. . . Gladys goes left and Clyde marches right. They circle around the track and meet at the other end. When they meet Clyde's right foot lands, at the same instant, so does Gladys' right foot. And they bump into one another. They're still in phase, and dazed.

Now do it again, at a different school on a different track. This one was laid out by a sloppy designer and the side that Clyde usually travels is slightly longer than the other side. So when Gladys reaches the opposite end, she marches in place because Clyde's not there yet and when he does arrive, his cadence may not match hers. That different path length made them go from originally being in phase, to out of phase.

If your job is to determine whether the sides are the same length, you could just measure them with a tape measure (that's what I'd do). . . or you could employ Gladys and Clyde to perform their routine in front of you. If they get to the end and are not in phase, then you know you've got a badly designed track on your hands.

Or let's suppose that on Gladys's side of the track, the long stretch has been replaced by an airport moving sidewalk going in her original direction. While Clyde encounters an identical moving sidewalk that's going in the other direction. Strange, right? So she's helped along and he's hindered and she obviously gets to the finish before Clyde. Again, they would be out of phase since she got the benefit of a moving medium in which she would travel and his forward progress was hindered by that medium.

That's a way to imagine the Michelson Interferometer. It's a device to take a light beam and cause it to travel two different paths and then to see whether they are still in phase when they are brought together.

So they could be out of phase because the paths they travel (the *optical path*, OP) are different and/or because the medium that they travel in (the ether) helps one of them along because of the interferometer's motion relative to that medium (the moving sidewalk).

Back to Bob and Doris: In the Michelson's Interferometer, the Bob-wave is made to travel perpendicular to the motion of the Earth through space and the Doris-wave is made to travel with, and against that motion. Michelson would measure precisely a finite speed for the Earth relative to the ether, by observing how out of phase the two

paths are and he could do it with a precision that he'd know from understanding his instrument.

That was the plan, but the engineering and instrumentation was formidable and while Humboldt University was prepared to give Michelson a downtown Berlin laboratory in the basement, there was very little funding for the equipment.

15.1.4.1 With The Phone Guy's Help

Simon Newcomb came to the rescue again. He seemed to know everyone and of course that included his friend Alexander Graham Bell who came through with sufficient financial support to allow Michelson to collaborate with a German optical company to construct his first interferometer. So in 1881 Michelson built an exquisitely precise device which combined waves in exactly as the river analogy required.

Let's look at Figure Box 15.4 on page 135. After you've read the material in that Box, return to this point ↶ and continue reading.

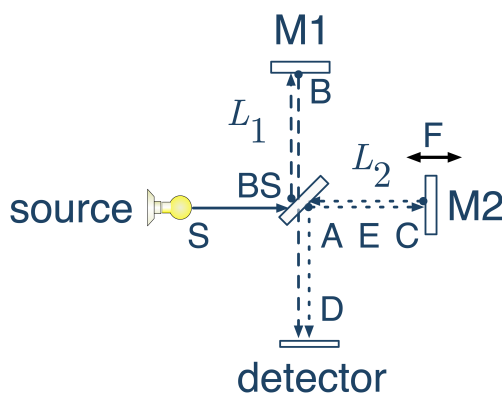

Figure 15.4

This is a simplified plan view of the Michelson Interferometer as seen from the Earth, without any ether. The element in the center at A is called a Beam Splitter (BS) or “half-silvered mirror” (think of a teleprompter). It takes a beam of light and separates it into two perpendicular, identical rays, one passing through and one directed perpendicularly. Let's follow the paths:

Path 1: Light from the source, S, is separated into the two paths at A by the BS oriented at 45° . Half of the light from S passes on through the BS to the right at

C. The other half is diverted into a vertical beam directed at a plane mirror, M1 at B (dashed rays). The distance from A to B is L_1 . That beam reflects from M1 back through the BS where again, half is transmitted down and half goes in the direction of the source (and ignored). The half that continues down stops at the detector, D.

Path 2: The light that went right through the BS to the right (now the dotted rays) is reflected at another mirror, M2 at C, as close to being perpendicular to M1 as can be arranged. It then passes back through BS, and yes, half of it then reflects down toward the detector at D. The distance from A to C is L_2 . Michelson strove to make L_1 be as close to L_2 as possible.

Now go back to page 135 and pick up where you left off.

The magic is in the path between A and the detector, D. Each beam started out as a partner of the other (Gladys and Clyde), and so they are initially coherent and they mix on that short path to D. If they are now slightly out of phase, the image at the detector will register that. How?

Well, back to Gladys and Clyde who are now in demand and decided to add to their act. Now there are 10 marchers. Ten marchers enter the track together, five on the left and five on the right. They split up like when it was just the two of them and take their paths—each of the 10 marchers never adjusts their pace. But wait. The marchers in the inside of the track travel a shorter distance than the marchers on the outside of the track. So the outside people travel further and are later than the inside people to travel less and get there faster. The middle marchers will meet exactly at the same opposite point, but the inside marchers will get there earlier and the outside marchers later. There will be phase-chaos when they meet. They will interfere with one another in different ways, the two opposite sets of five.

The same thing happens in the interferometer. The beams are not infinitesimal lines of light, they're broad (even made so with a lens, not shown, just after S) so the result is a bullseye pattern at the detector with the center being bright and then a dark-light-dark-light progression from the center. These are called "fringes" and where the light-dark regions are on the screen depends critically on the OP lengths that the beams travel... or their relative motion in the medium through which they traveled.

Now, what could make those two beams be out of phase? Any number of circumstances:

- If $L_1 \neq L_2$ then they will arrive at different times and so be out of phase when they combine.
- If either or both M1 or M2 are not perfectly perpendicular to the impinging light source, that will create a distortion.
- If there is a temperature difference in the air between the two arms, even that would affect the beams' differently.
- Or... suppose that we're back in the river and the medium that is doing the waving—the river or the ether—is moving relative to the setup, then from our simple Doris-Bob race, the two combined beams will appear to be out of phase because the perpendicular, dashed path, will win.

The first three ways to get interference are under Michelson's control: he must build the apparatus with great precision. The last way... Nature will determine that.

But he was really clever and even the first three ways of getting out of phase won't matter!

Here's the genius part: Michelson constructed his apparatus so that the whole thing could be rotated by 90° about a vertical axis. When that happens, then the two

beams trade places and the original fringe pattern shifts... the spot where light was bright and where it was dark, changes between the rotated and un-rotated positions. So he marked where the bright spots were and then rotated, and looked to see where they moved to.

That rotation not only cancels instrumental effects, but it also doubles the fringe shifting from nominal. Appendix ?? shows you how this comes about. The expected shift of the fringes comes from the path-length difference that would result from the speed of the Earth through the ether of v , the speed of light, c , and the two arms' lengths:

$$\delta L = \frac{v^2}{c^2}(L_1 + L_2).$$

The speed of the Earth in its orbit is about 30,000 m/s and the speed of light is about 300,000,000 m/s... so the shift is a tiny amount of

$$\delta L \approx 0.00000001(L_1 + L_2)!$$

The question is whether tiny instrumental effects might either mask a positive result, or signal a false positive result.

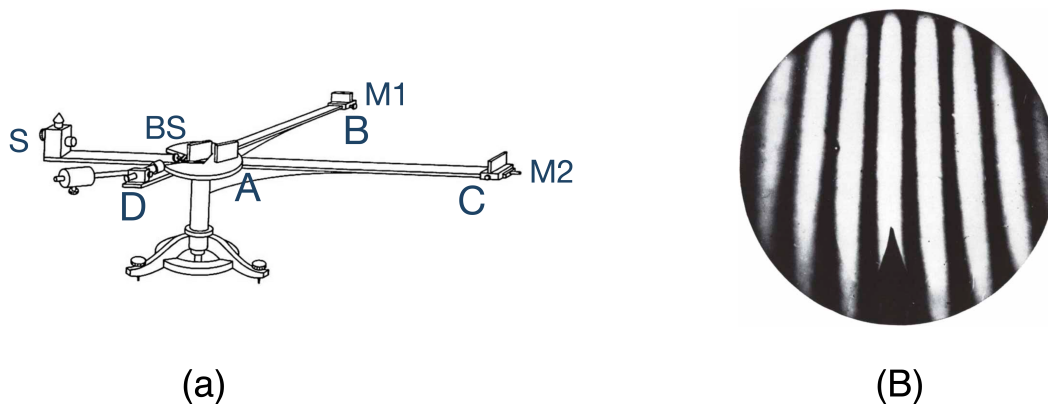

Figure 15.5: (A) On the left is a perspective engineering drawing of Michelson's prototype where I've labeled it like the sketch above. (B) On the right is a fringe pattern resulting from the apparatus (by the author).

His first prototype instrument had arms about a meter long and was finicky and delicate. Horse-drawn traffic outside of the lab building was so disruptive that the fringe pattern was unstable. So, he made the measurements in the middle of the night, but that was not sufficient. That was still unstable and so he subsequently moved it to a new lab at rural Potsdam, and then a second lab in the basement of that same facility. This was quieter but delicate still. In his publication later he noted that even stomping on the ground 100 meters away from the building would cause the interference patterns to disappear! So, taking data was exhausting. Plus, he had to physically rotate the entire apparatus that 90° by hand which was hard to do precisely. Figure 15.5 is a perspective engineering drawing from Michelson's Potsdam apparatus and also a candidate Michelson Interferometer fringe pattern is shown.

After more than six months of painstaking work, he published his results and wrote to his benefactor:

Heidelberg, Baden, Germany

April 17th, 1881

My dear Mr. Bell,

The experiments concerning the relative motion of the Earth with respect to the ether have just been brought to a successful termination. The result was however negative...

At this season of the year the supposed motion of the solar system coincides approximately with the motion of the Earth around the Sun, so that the effect to be observed [sic] was at its maximum, and accordingly if the ether were at rest, the motion of the Earth through it should produce a displacement of the interference fringes, of at least one tenth the distance between the fringes; a quantity easily measurable. The actual displacement was about one one hundredth, and this, assignable to the errors of experiment.

Thus the question is solved in the negative, showing that the ether in the vicinity of the Earth is moving with the Earth; a result in direct variance with the generally received theory of aberration...

N.B. Thanks for your pamphlet on the photophone.

The speed of the ether relative to the Earth seemed to be zero. He believed it to be a failure, the first in his so-far, distinguished career as the young King of Optics.

15.1.5 Getting Serious: Michelson Meets Morley

The work in Potsdam was exhausting and discouraging and so after his experiment and Ph.D. programs were done, he and Margaret and (now three) young children explored the German countryside with Albert watercoloring and studying. They spent some time in Heidelberg where he worked in another lab and improved his ability to produce half-silvered mirrors. After a pleasant summer, they went back to Paris (Margaret's stomping ground from her youth) and Albert spent time in the École Polytechnique where the legacy of Foucault lived on. The next fall and winter Albert repeatedly failed to show his skeptical French colleagues that his interferometer worked! Eventually, he succeeded with relief... which was short-lived. One of them showed him that he'd made an arithmetic mistake in his ether publication's analysis which served to reduce the fringe shift. About that same time, Hendrik Antoon Lorentz (1853-1928, Chapter ??) found the same mistake. That raised the stakes as we will see, Lorentz was the first to begin to think seriously about what an actual null result might mean.

15.1.5.1 Cleveland

The most significant thing to happen in Cleveland, Ohio before the installation of the Rock and Roll Hall of Fame was Albert Michelson's arrival.

When Michelson's time in Europe was complete, his future was uncertain and so he was delighted to discover that colleagues had interceded on his behalf to offer him a faculty position at the brand new Case School of Applied Science in Cleveland, Ohio. (This is now the very fine Case Western Reserve University.) With a salary of \$2000 per year and \$7500 for equipment, and his graduate education under Helmholtz, he readily accepted the position, resigned from the Navy, and in 1881 re-established his light-speed measurement work in Cleveland. A structure was erected for his lab and he reassembled as much of his Annapolis equipment as he could find. As his daughter pointed out, "Michelson's experiments had a way of costing far more than had been originally expected." He ran out of money and was assisted by... Newcomb, again. His eventual result of 299,853,000 meters per second (0.02%) precision stood as the standard for four decades.

In 1884 while on a trip to Montreal to attend a scientific conference, he met Edward Morley (1838-1923) on the train—a senior Western Reserve University² and chemistry professor who was good with his hands in a lab. They struck up a friendship and determined to work together upon their return. Michelson had the pleasure of hearing his results discussed in lectures at the conference and Simon Newcomb made sure to introduce him to all of the attendees of note. As a result he found himself becoming friends with John William Strutt, 3rd Baron Rayleigh—future Nobel Laureate and another king of physics who invited him to Baltimore for a marathon 20 lectures on

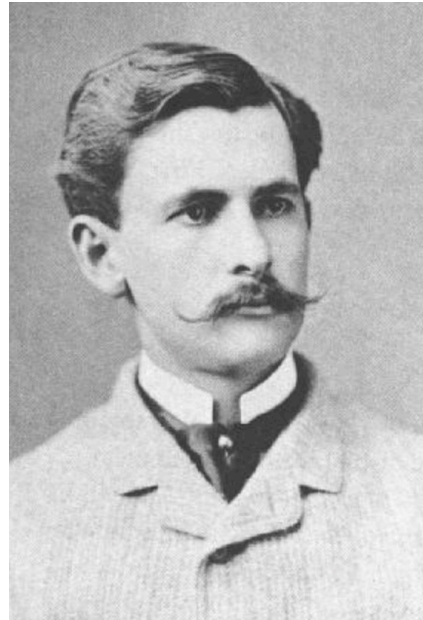

Figure 15.6: Michelson in 1887, around the time of the Michelson-Morley experiment. (Practical Physics, Millikan and Gale, 1920, scanned by B. Crowell)

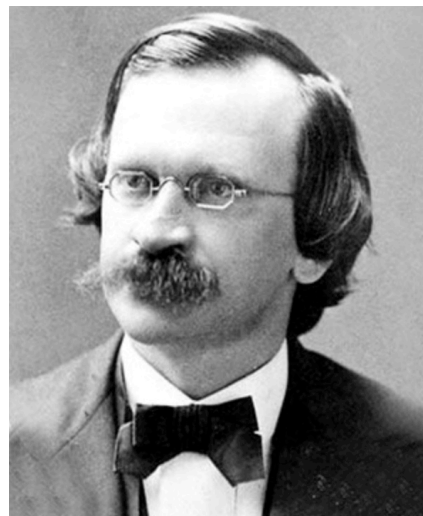

Figure 15.7: Edward Morley (1838-1923)

²Case University and Western Reserve University were adjacent, and now combined

physics at Johns Hopkins to be delivered by Sir William Thomson, the future Lord Kelvin. One of Kelvin's emphases was the elastic properties that the ether must have for the planets to move it aside as they pass. Thomson paid no attention to Maxwell's electromagnetic theory as Hertz was still three years away from his experimental confirmation in Helmholtz' lab.

Michelson had given up on the ether measurement, believing it to be a failure but in Baltimore Rayleigh persuaded him to try again and he and Morley resolved to do that experiment together and to use an interferometer as the device in Main Hall on the Case campus. With modifications designed to mitigate the problems of the Potsdam effort, surely, that would yield a positive result.

As a warm-up they decided to try to repeat Fizeau's 1851 experiment that suggested that the ether is dragged, but with better engineering than 30 years before. (We'll look at Fizeau's work in Chapter ??.) They nearly got the experiment assembled and ready for data when the first of a series of terrible events happened.

Events that launched a three year period of triumph and disaster.

Morley wrote:

"I can only guess at the stresses which brought about his illness. Overwork—and the ruthless discipline with which he drove himself to a task he felt must be done with such perfection that it could never again be called into question."

Michelson wasn't sleeping, nor eating. He'd been a tennis champion on campus, but now only worked. Eventually he collapsed and on September 19, 1885 at the age of only 33, Margaret had him committed to a nerve specialist in New York. Again, from Morley:

... Mr. Michelson of the Case School left week ago yesterday. He shows some symptoms which point to softening of the brain; he goes for a year's rest, but it is very doubtful whether he will ever be able to do any more work. He had begun some experiments in my laboratory, which he asked me to finish, and which I consented to carry on.

What happened next is astonishing. He recovered in two months and wrote to Morley to inquire as to the experiment and learned that Case University had hired his replacement! It gets worse.

His doctor wrote:

... his [Michelson's] wife has urged me to shut him up in an asylum which I promptly refused to do. Mr. Michelson is one of the brightest men of this country if not of the world in his chosen study. He is an accomplished man, very popular with those who know him. . . Professor Michelson's most temperamental fault is a tendency to emotional acting, but I cannot say that it is unduly expressed, or that he ever acts without proper and adequate stimulus. . .

Fortunately, he recovered by December and returned to try to piece together his career and his marriage. He struggled with the knowledge that Margaret tried to commit him to an asylum against his will and as a result their marriage was troubled until it ended 13 years later. Upon returning to Cleveland, Michelson moved himself into his own quarters in their large house and by many accounts, his personality seemed to change after these two betrayals: by his wife and his university.

While healthy and ready to resume his research, the Case Board of Trustees hadn't done their worst: They indicated that they would be happy for him to return to the faculty, but he'd have to take a considerable cut in his salary since they had hired his replacement for the year. Michelson had to pay for his own stand-in.

In any case, after another desperate infusion of funds, he and Morley completed their first experiment and confirmed the Fizeau result: the ether seems to be dragged along with the Earth. He was urged by many then to repeat the Potsdam experiment with better precision as the ether-chaos was unbearable for the community. Life settled down for Michelson. Still bruised, he and Margaret worked towards some measure of reconciliation. He played tennis and painted and thought about how to do Potsdam better. But the Universe was not done challenging him yet.

Sometime between midnight and 2AM on October 27, 1886 Main Hall on campus spectacularly exploded. In the aftermath, Michelson and Morley were able to salvage much of their apparatus and they reconstructed it in Morley's, now cramped, Western Reserve chemistry lab. That's when it got serious. They set out to reduce as many of the systematic uncertainties that the Potsdam experiment encountered and succeeded.

15.1.6 The "Michelson Morley Experiment"

What followed during the summer of 1887 is arguably one of the most important experiments in the history of physics, the "Michelson-Morley Experiment." The issue was to repeat the Potsdam work, but improve the accuracy by mitigating the drawbacks of Michelson's original design. They tried to damp the vibrations that plagued the earlier measurement by building the new apparatus on a huge, heavy sandstone slab that floated in a donut-shaped channel of mercury—a dangerous environment, not allowable today. This isolated it vibrationally and allowed the experimenters to keep the whole instrument in constant, smooth rotation, slowly, so that the directions of the arms are constantly and uniformly changing with respect to the ether direction. Now all they needed to do was observe *any* shift in the fringe positions. That would eliminate any potential bias and it relieved him from the disruption that rotating his Potsdam apparatus by 90° might have caused.

Furthermore with high quality mirrors the two L_1 and L_2 light paths were increased by reflecting them back and forth to an effective overall length of 11 meters—more than a factor of 10 longer than Potsdam—greatly improving the precision as well.

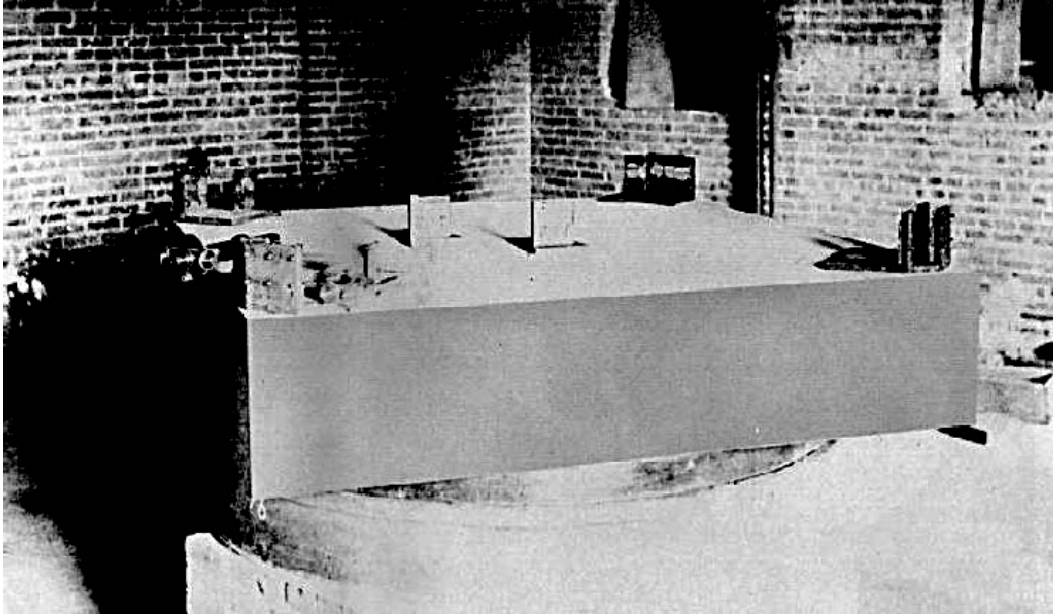

Figure 15.8: The Michelson-Morley apparatus on its huge concrete, rotating slab.

Remember that the tiny shift in optical length is proportional to the sum of the lengths of the two arms, so that factor of 10 is significant.

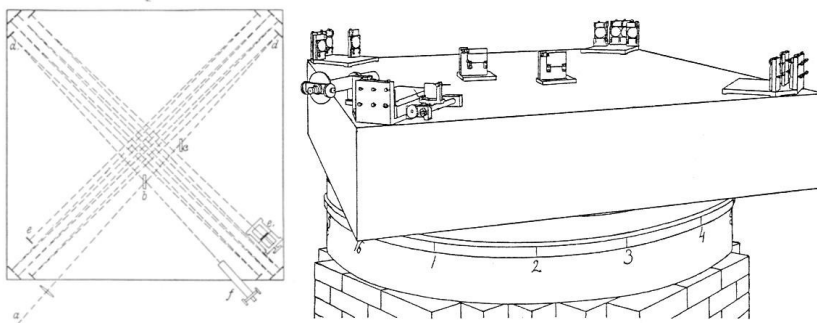

Figure 15.9: Plan and perspective engineering drawings of the Michelson Morley Experimental apparatus.

So on six days in July of 1887 they did their experiment walking around the circle looking into the eyepiece all the while in 30 minute shifts each. Figure 15.10 shows their results:

The vertical axis is the amount of fringe shift in fractions of the wavelength of the light. The sine-wave curve is what they would expect to see as the apparatus rotated through a circle based on the Earth's speed and a stationary ether, *but they drew it in the plot reduced by a factor of eight.*³ The sort of sad, flat curve is what they

³This is not always appreciated when Figure 15.10 is reproduced.

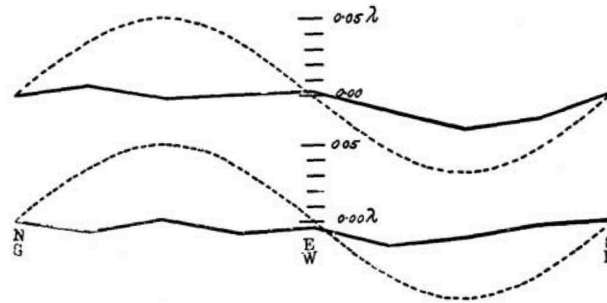

Figure 15.10: The Michelson Morley apparatus showing the slab with the optics on top and the donut of Mercury on the bottom. As they rotated the slab, and hence the interferometer, if the speed of the Earth relative to a stationary ether were real, then they would expect to see the result shown as the dashed curve. The broken solid lines is what their results showed.

actually measured. By reducing the expected curve, the dramatic difference with the expectation—and the tiny flatness of their result—isn't as prominent as it should be. This really is zero: no effect is seen. It's the most important measurement of zero, well, ever.

In August, 1887, Michelson wrote to Lord Rayleigh who had encouraged him to return to the ether experiment:

"The Experiments on relative motion of Earth and ether have been completed and the result is decidedly negative. The expected deviation of the interference fringes from the zero should have been 0.40 of a fringe — the maximum displacement was 0.02 and the average much less than 0.01—and then not in the right place.

"As displacement is proportional to squares of the relative velocities it follows that if the ether does slip past [the Earth] the relative velocity is less than one sixth of the Earth's velocity."

For Michelson it was a failure. Either the ether moves with the Earth or there is no ether. Or something else. Neither Michelson nor anyone could imagine that the ether didn't exist. And even after Einstein's dismissal of the ether on different grounds, Michelson himself couldn't get rid of the ether in his mind during the rest of his life.

After their result became public, the physics world began to pay anxious attention. An explanation was needed. But he never liked that result and was discouraged enough to abandon their original run-plan to do the measurement at different times of the year, and presumably different angles with the ether.

He was done and he never returned to this experiment again.

15.1.7 Michelson and Chicago

By 1888 Michelson had become unhappy at Case—his illness, Case’s response, the fire and the refusal to rebuild his lab, and trouble at home weighed on him. But that malicious universe still wasn’t yet done with Michelson. The family was to suffer through two more calamities in 1887. A cook actually robbed them of their jewelry and other valuables (which were recovered in another town). And, in later in that same year a maid accused Michelson of sexual assault actually leading to his arrest at home with headlines in the paper! Blackmail had been demanded and Michelson, Morley, a lawyer, and the Cleveland police actually set up a sting operation to get the perpetrator to expose her plot exonerating Michelson. Quite another year in Cleveland.

So he was ripe for the picking. When Clark University was formed in Worcester, Massachusetts and started recruiting scientists in 1889, Michelson jumped at the chance to restart his program as the first Chair of Physics with finally adequate financial and technical support. In retrospect, Case had made a terrible mistake.

Off they went to the New England countryside. But after a promising start, it wasn’t a match made in heaven for any of the talented faculty recruited to Clark. By 1892, Michelson and 12 of the 16 scientists on Clark’s faculty resigned in unison because of an unbearable meddling by the university president who was on an entirely different course from the founder and financial benefactor, Jonas Clark. It was a mess. Today, Clark University is a thriving institution. But another one owning the distinction of losing Michelson. This time to the new University of Chicago in 1892, along with the 11 others from Clark. The University of Chicago promised big and delivered.

15.1.7.1 A Meter

Michelson’s arrival in Chicago was delayed. The International Bureau of Weights and Measures in Paris recruited him for an important job: determining the most precise length of the standard meter. The French metric system relied on a platinum bar housed in Paris which defined 1 meter according to the original 1791 definition: 1 m = one 10-millionth of the distance from the north pole to the equator on a meridian passing through Paris. More precision was needed since the Earth is a non-spherical, geologically active object—it’s not great as the basis for a standard length. And, even though there was a “standard” platinum bar kept at a controlled temperature in Paris, each nation, even cities, had their own copies of the original standard meter. So there were lots and lots of “meters”!⁴ Sir Humphrey Davy and Maxwell suggested a standard which could be independently replicated using a natural phenomenon of some sort: the wavelength (for length) and frequency (for time). . . a repeatable observation of an atomic transition’s color.

⁴Also, there was real concern that were a war to break out that the unique platinum bar could be destroyed.

One of the outgrowths of the Michelson-Morley experiment at Case (Western!) was the realization that the interferometer could be used for other purposes. For example, by making one of the arms moveable and with a careful micrometer measurement of just how far it moves, one could watch the interference fringes change place, a half-wavelength at a time. By marking where one peak was, changing the distance of the movable mirror would march the peak across the eyepiece and when a trailing peak lined up at the origin spot again, the lengthening would correspond to one half of a wavelength. So, one could precisely determine the wavelength of spectral lines of various light sources. In 1887 they proposed using interferometry as the tool for precisely measuring the meter and proposed that the spectral lines of Sodium light might serve as the source. (Sodium vapor emits a bright pair of yellow emission lines.) Then they decided Mercury's green line would be suitable, but discovered that Mercury's line was actually quite complicated—many lines. So they actually made a discovery about the element Mercury! Of course they could then measure the spectral lines of other elements an important addition to the nascent science of spectroscopy.⁵ They kept at it and found that the red Cadmium spectral line ($\lambda = 6,438$ where an Angstrom is 10^{-10} meters) was singular and could become a calibration point.

That's what the International Bureau of Weights and Measures wanted. They invited Michelson to come to Paris and find an emission-line standard for a meter. This he did with characteristic precision and accuracy with a result that lasted for four decades. After being repeated in 1905, two years later the standard meter became 1,553,163.5.180 wavelengths of that Cadmium red line's wavelength with an uncertainty of 0.08 parts per million. This measurement was referenced as a part of the justification for Michelson's Nobel Prize in 1907.

When his work was done, he reported to duty at the new University of Chicago. Margaret bought a house on the East Coast and his family didn't join him for a while.

15.1.7.2 University of Chicago

The University of Chicago's was born out of the commitment of a handful of private (wealthy) citizens with a vision of a world-class research university. The United States' university system, and so its scientific expertise and training, was rudimentary compared to that of Europe's and Marshall Field and other Chicago businessmen were determined to compete. The new Ryerson Physical Laboratory was completed in 1894 and Michelson and others moved in. Students who could pass the difficult entrance examinations came from all over the world. It must have been a heady time as the new faculty knew that they were participating in something special in the United States. He was to spend the next 40 years there.

⁵They and others became less interested in the interferometer for this purpose and it went out of style. Only to be resurrected in the 1950's as "Fourier transform spectroscopy."

The next couple of years were replete with honors: the Société Française de Physique, the Royal Astronomical Society, the Cambridge Philosophical Society, and the Société Hollandaise des Sciences. But they were not without heartache as well.

In 1897, the Michelson's shocked the tight-knit faculty when Albert moved to a hotel. Margaret sued for divorce and he agreed to support his three children (Albert Heminway, Truman, and Elsa) with \$10,000. The court proceedings were humiliating as the children had been trained to describe cruelty at his hands in their upbringings and he vowed to never see them again.

While his divorce was still pending, Michelson met Edna Stanton, the daughter of a former diplomat to Russia (she lived there for 12 years) and a German mother. She was radical and a free-spirit. . . and 20 years Albert's junior. Nonetheless, they courted, married in 1899, and subsequently had three children. One of those daughters was Dorothy Michelson Livingston, the biographer of her father (?).

His time at Chicago was nonetheless productive and pleasant. His students enjoyed him. He played tennis regularly and had a professional and well-staffed laboratory and was able to watch his new family grow up. He was in demand around the country and the world and took on new and engaging experiments with enthusiasm and his characteristic talent for precision optics. The projects he took on included:

- The measurement of the radius of a star—initially the red giant, Betelgeuse using interferometry—essentially capturing light with two telescopes and letting them interfere. In effect this increases the resolving power (or effective size) of any single telescope by a considerable factor. This is a standard technique especially in radio astronomy today.
- He continued his speed of light measurements and was engaged in a long-baseline experiment in California when he passed away.
- He created and perfected the creation of very precise diffraction gratings with an engineered instrument in the basement of the physics building. They were the best in the world and



Figure 15.11: Michelson around the time of his Nobel Prize. (AIP)

required weeks of patient, delicate fabrication.

Oh. And he won the Nobel Prize in 1907, the first American to do so and the first Jew to win the physics prize. The award was not for the ether experiment, as Special Relativity was still only a year or so old and Einstein was still unknown. Michelson's award reads: "For his optical precision instruments and the spectroscopic and meterological investigations carried out with their aid."

Michelson died in 1931 at the age of 79 in Pasadena, California where he was engaged in a multiple experiments to improve the precision of the determination of the speed of light. He and Edna had retired from the University of Chicago and moved the previous year so he could focus on the culmination of nearly a half century of steadily improving this measurement. He had had multiple operations for prostate and intestinal disease with multiple infections (before the time of antibiotics), often writing and working from a bed. This final experiment involved the construction of an evacuated tube about a mile long in the mountains of Irvine Ranch near Santa Ana, California. With multiple reflections, the path length was effectively more than 8 miles. His biggest hurdle? The whole Earth. By the time he ended his life's work, his precision battle was against tiny geological shudders in the crust of a major mountain.

Today the determination of the speed of light is exquisitely precise using lasers: and for many years the technique is still essentially the same one that Michelson pioneered while he was in the Navy. That's changed in the last 50 years as is described in the "More" Section 15.2.6. Furthermore, his use of the interferometer for pure-science measurements is now ubiquitous for all manner of engineering and scientific purposes. You can read a bit about that in the "More" Section 15.2.1. Likewise, his original notion of measuring the size of a star using two small, but widely spaced optical receivers and letting the interfering pattern determine the angular size of the star is now the standard technique of optical and radio astronomy for huge telescopes around the world. Again, find this story in the "More" Section 15.2.2. Finally, not only is the Michelson Interferometer a standard bench instrument in optics labs everywhere it is the principle deployed in the LIGO experiment that has recently discovered Gravitational Radiation and has initiated a whole new branch of astronomy by studying the collisions of neutron stars and black holes.

A nice side-story to the Nobel award was in the crowd who surround him after his Nobel lecture in Copenhagen. A young man approached him to say, "You don't know me. I am your son." The bitterness of the divorce from Margaret left Albert estranged from his two sons and daughter 11 years previously. Young Albert had graduated from Harvard and at 29 was the American consular agent at Charleroi, Belgium. He'd been in Italy at a meeting, saw that his father had won the Prize and was bound for Stockholm and so Albert Junior traveled north to meet him. Michelson abandoned his ceremonial and social plans and spent time with his first-born son.

15.2 More of the Michelson Story

15.2.1 His Interferometer

As we saw in Chapter ??, Michelson didn't invent the idea of light interference as a measurement technique, but he perfected it and most interestingly, extended its application to modern-day uses. We think of the Michelson Interferometer as the instrument that dealt the devastating blow to the ether and the first definitive (if originally misunderstood) experimental support for Special Relativity. But without the Michelson Interferometer your contact lenses would be uncomfortable if they could be produced at all. In fact, the two side-projects that he engaged in formed the basis of entire industries and two entirely new branches of astronomy. Recall that he analyzed the Mercury atomic spectrum and discovered new emission lines, he converted the physical standard meter bar to an optically-defined standard for the meter, and he measured the size of planets and stars. Let's take a short tour up to the present day.

15.2.1.1 Spectroscopy and Materials Science

One of the early uses of the Interferometer was in atomic spectroscopy. Just as Michelson discovered that some apparently single emission lines from some elements were more than one line—doublets—others were able to use his instrument to more precisely pin down the precise wavelengths of many atomic transitions, which became increasingly important as quantum mechanics began to catch on.

Back in Figure ?? the point labeled "E" is a location where a sample—a gas or a transparent solid, like glass—can be placed so that the beams headed left and right travel a slightly different "optical path" length from that of the reference beam traveling up and down. The interference can be attributed to the sample at E, like the refractive index of a piece of glass. Movement of one of the mirrors, intentionally changing the path-length to study the changes in the interference pattern, also allows for pinning down the sample's material features and this can be done with a micrometer, or very delicately, with a piezoelectric crystal.

Industrial applications of interferometric tools abound, and the Michelson Interferometer is still a front-line instrument. Computer control, CCD readouts (like your phone's camera), and on-board computation and digital display make fast work of characterizing the material properties of sample surfaces. Suppose you need for a silicon substrate to be perfectly smooth, you could try to mechanically determine the tiny peaks and valleys of the surface, but that might harm the surface. If however, you reflect a light source from the material across its surface and feed that into a Michelson interferometer simultaneously comparing it to a reference light source (typically a Helium-Neon laser), one can convert the patterns of the interference of source-reference lights and the probe's position across a surface to see if a surface is sufficiently flat. These devices can even be integrated into a large scale set of probes robotically doing quantity control of many pieces. Depth

measurements can also be done in transparent and semi-transparent materials. Your contact lenses must be smooth, and they must have a precisely controlled curvature and interferometric tools are employed in their manufacture.

Now there are many kinds of interferometers beyond the original Michelson configuration. The Mach-Zehnder Interferometer is deployed in many integrated optics applications. The Fabry-Perot Interferometer is a device that allows a beam of light to reflect back and forth in a cavity (the “etalon”) in which the width of the eventually emerging beam is very, very narrow. . . with wavelength resolutions of one part per million. This can serve as a reference point for, say optical fiber telecommunications. Or for spectroscopy. They can be used as lasers in some applications, as the multiplication technique is similar. It can be used to identify very small atomic transitions in astronomy, like in the study of the Sun’s atomic composition. There are dozens of other forms of interferometers on the market for specialized applications: Fizeau interferometer, Sagnac interferometer, Twyman-Green interferometer, multi beam interferometer. . . and the list goes on!

Albert Michelson had no clue how his original idea would impact technologies that he could not have dreamed of.

15.2.2 Astronomy

“He took light from either side of the star and brought it together again with mirrors in his interferometer. It’s got a linear diameter of 240 million miles, almost as large as the orbit of Mars. Light from Betelgeuse would take 150 light years to reach the earth, and it is 2300 times larger than our sun.” As explained by Michelson’s young daughter, Dody, to a group of reporters who showed up at the Michelson home just as she arrived home from school. They had heard a rumor of his result.

Michelson did something rather amazing in 1920. He relied on interferometry to measure the actual size (in miles). . . of stars. His initial dabbling in astronomy became one of his most enduring and fruitful applications, responsible for the creation of at least two entirely new branches of astronomy.

15.2.2.1 The Limits of Telescopes, or Eyes

Recall in Chapter ?? that I invented the image of a “can” to represent the cross-section of some container that gathered light from an image and projected it to where an image is recorded. It could be your eye, your camera, or for our purposes here, a telescope. All research telescopes now are of the Newtonian sort with light impinging on, and then reflecting from a mirror in the back to a collection device, now a CCD array which registers the intensity of the light that entered the telescope. Also remember the Raleigh Criterion that represents the ideal critical opening angle between two objects that serves as the dividing line between when they can be seen as two separate things and when they’re too close together and cannot be resolved.

Here's that demarcation angle again:

$$\theta_R = 1.22 \frac{\lambda}{D} \quad (15.1)$$

Instead of leaves on a bush, if our goal is to distinguish *two stars* which appear from Earth to be close-by one another, we may or may not be able to do that with our telescope depending on its aperture size, D . Figure 15.12 (a) shows the situation for capturing the image of one star: the bullseye intensity image at the bottom is what the CCD array would capture and the slice of that image, the Intensity Curve (IC) is sketched on the "mirror" of the telescope.

The two-star situation is sketched in Figure 15.12 (b) where now the IC curves from each star overlap reflecting the overlap of the intensity diagrams. The opening angle θ_o is shown in the diagram and the question is: can the observer see two stars or one blurry image? Well, if $\theta_o > \theta_R$, then they can be resolved. I described the

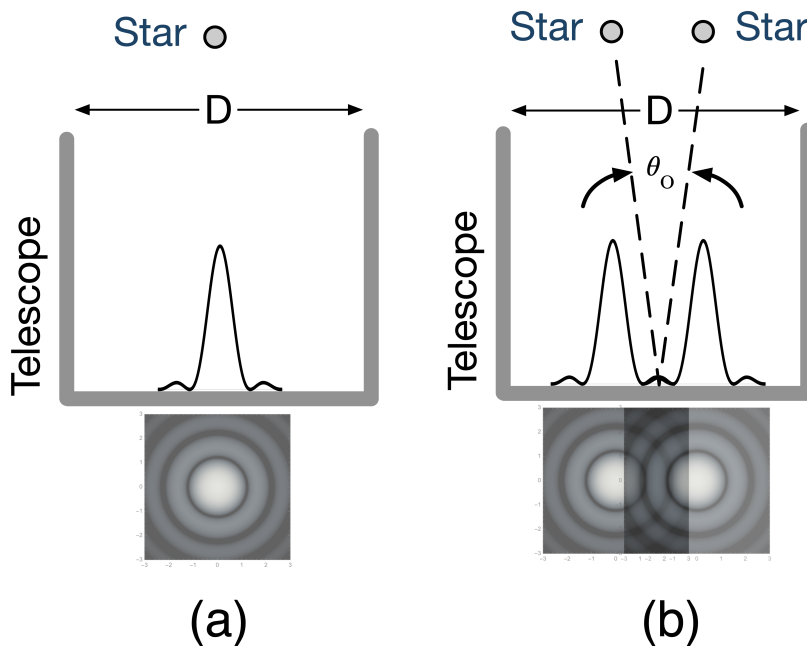

Figure 15.12: In (a) a single star is captured in a telescope of aperture D . The bullseye intensity pattern is shown at the bottom and the Intensity Curve is sketched at the receiving end (mirror) of the telescope. In (b) two stars are viewed with each creating its own intensity pattern, and overlapping Intensity Curves. The opening angle to the stars is shown as θ_o .

opening angle and the resolving power of your eye in Chapter ?? and we can do the same thing for the resolving power of a telescope.

15.2.3 Actual Telescopes

Just like our eyes, telescopes' ability to resolve and separate astronomical objects from one another is restricted by the Rayleigh Criterion. The largest reflecting

telescope in the world is the 10.4 meter diameter Gran Telescopio Canarias (GTC) in Roque de los Muchachos Observatory in Spain's Canary Islands. How well can it do?

Astronomers have a few ways to define distances and the "light-year" is particularly insightful. A star that's 1 light-year away means that when we see its light, it was emitted 1 year ago. So a light-year is the distance that light travels in one year. For the record, that's 5.8786×10^{12} miles or 9.4607×10^{12} km. The closest star to Earth is Proxima Centauri, which is about 4 light-years away. If you used your cell phone to announce to your brother that your family had just had a baby girl, by the time residents on a planet around Proxima Centauri get the happy news, that baby girl is four years old. As another example the thickness of the Milky Way is about 1000 light-years deep. How about GTC?

From Equation 15.1 the Raleigh angle for GTC is about $\theta_R = 3.7 \times 10^{-6}$ degrees so if the distance to the Andromeda Galaxy is 2 million light years away from GTC (and again, perfect atmosphere), then GTC can distinguish objects in Andromeda that are within 0.13 light years from one another. (That's more than a thousand times larger than the solar system.) So, this is incredibly tight resolution... but actually *not* achievable on Earth because of the effects of the atmosphere. By contrast, the Hubble Space Telescope can resolve features inside of the Andromeda galaxy to about a half of a light year even though its mirror's diameter is only about 2.5 meters. Ah. But it's outside of the atmosphere. The Raleigh Criterion for the Hubble is about 1.6×10^{-5} degrees, not so different from that perfect GTC value, is it. The atmosphere makes a big difference.

How can we see objects better, or equivalently, see objects even further away? We have insight for that from Equation 15.1 You might imagine two ways: make the telescope bigger (increasing D would make θ_R smaller) and/or build an instrument sensitive to smaller radiation wavelengths (decreasing λ would make θ_R smaller).

Good ideas, but we've about maxed out on size of telescopes since gravity becomes your enemy for really massive things that must move delicately across the sky. And going to smaller wavelengths is tough because of atmospheric absorption is almost total for the wavelength bands shorter than visible light, like ultraviolet light, X-rays, and gamma rays. Telescopes operating at these wavelengths do exist, but they're all in orbiting satellites and so necessarily small—but very nice tools. The cosmic wavelength band that is completely accessible on Earth is in the radio region, which ranges from wavelengths of centimeters to many meters long. And many interesting astrophysical phenomena emit radiation in the radio region. Looking back at Equation 15.1, increasing the wavelengths of interest from a half a micron to multiple meters seems to go the wrong way! We'll talk about that in a bit. But let's unravel Michelson's neat idea.

You probably wondered what this had to do with interferometers.

15.2.4 Michelson's Star Project

To understand his approach, do you remember the Double Slit experiment of Thomas Young in Chapter ??? A single light source was sent through two slitted openings in a piece of paper and the light from those two regions fell on a screen and formed the picket-fence, light-dark rows indicating that the beams had mixed with one another (positively, for the bright lines and destructively, for the dark ones) after bending (diffracting) as they emerged in the two finite sized slits. We're going to revisit this idea. The distance from one light row to the next row is related to the space between the slits, the light wavelength, and the distance from the screen to the paper that has the slits. If you knew the distance from the screen to the paper, you could calculate the distance between the slits. So there's quite a lot of information encoded in that picket fence interference pattern that is inside of the envelope of the single slit IC.

Well, suppose that instead of slits, these two sources of light were actually two stars? How well can we see two stars? It's a little like Young's problem but a bit different. There's a trick.

15.2.4.1 Optical Interferometry

The almost magical tool was first suggested by Fizeau in 1865 who suggested putting a cover—a mask—on the aperture of a telescope which has two small holes in it, a distance b apart. If one looked at a star, the light would get to the mirror by passing through two holes, much smaller than the (now covered) whole telescope aperture. This would replicate the Young Double Slit situation with starlight appearing on the mirror from two interfering sources. The resulting picket-fence pattern, again, has lots of information buried inside of its wiggles.

Now suppose that the telescope with its two holes in the mask is aimed at *two stars* which appear to be close by one another.

Please look at Figure Box [15.13](#) on page [153](#) to get a feel for this. After you've read the material in that Box, return to this point ↩ and continue reading.

As you saw in the Figure box each would create it's own Young-like pattern and they would interfere with one another at the mirror creating a complicated curve that would not look like either one separately. Now, *that* combined image has lots of information in it!

In Figure 15.13, the distance between the two holes in the mask—the “baseline”—is b . The creation of those competing interference patterns actually increases the resolution of the telescope from the opening angle of the whole telescope opening of D . In some sense, the much finer picket fence interference contains within it finer resolution information and just how much actually depends on b . So much so, that the critical resolving angle, which I'll now call $\theta_{\text{interferometric}}$ is much, much smaller

than the telescope itself.

$$\theta_{\text{interferometric}} = 1.22 \frac{\lambda}{b} \quad (15.2)$$

(Remember that λ is the wavelength of the star's light...typically about 500 nm, and D is the aperture in meters.) Compare Equation 15.2 with Equation 15.1. For the new resolution of this two-hole system, the D in the denominator in Equation 15.1 has been replaced by b . The *larger* is the b , the *smaller* is the resolving power of the fringe analysis of an image. Something interesting happens that Michelson toyed with in his lab at Clark University...and then dropped for decades.

Now, you might think that b would always be smaller than D , so what's the advantage? Stay tuned.

FIGURE BOX 15.13

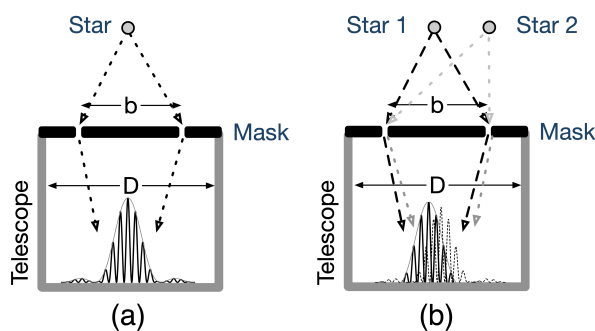

Figure 15.13

velope of the overall telescope's opening as shown.

In (b) we now expose the telescope to two point sources of light, namely adjacent stars. Here, I've drawn one overhead and the other to the right so the two fringe patterns mix in a complicated way as you can see depicted. But the opening angle between the two stars, θ_0 — is encoded in the complicated pattern that is recorded and a mathematical analysis reveals the opening angle, teased out of the fringes.

Now go back to page [152](#) and pick up where you left off.

15.2.4.2 One Star's Width

Fizeau's suggestion—and it's disputed as to just how aware Michelson was of this idea—was that suppose one was not looking at two different stars, *but two sides of a single star*. The thinking is that a star's disk is a combination of many individual point sources of light. One might be able to actually untangle the mixed interference pattern from a single star into measuring the opening angle subtended by the width of that star to determine its actual size. All you'd need was to know how far away it is, but what you'd actually measure is the opening angle of that star's width.

Appendix ?? goes into more detail on how this works. In a nutshell, as one changes

the baseline in a two-hole mask, that complicated, picket-fence interference image changes in its clarity. Suffice it to say that if the baseline starts out short, the picket fence will be brilliant—a clear distinction between the bright lines and the dark lines. As the baseline distance is increased, that distinction blends and at a particular value of the baseline distance...it becomes blurry. No longer any obvious lines. Let's call that critical baseline distance, b_{zero} where "zero" indicates that the clarity has gone away.

If you keep expanding on b , then the clarity of the lines actually begins to return, you see the lines again...and then will again diminish, and then return as b continues to expand. Michelson did the mathematics and invented a measure of that clarity, called "Visibility" or sometimes now, "The Michelson Visibility," V . If $V = 1$ the clarity is at its highest and the two stars are not resolved. If $V = 0$ then the clarity has gone away. However, Michelson calculated that at that particular zero Visibility point, the opening angle between the two stars has a very particular value, which I'll call θ_{zero} ⁶:

$$\theta_{\text{zero}} = 3.83 \frac{\lambda}{\pi b_{\text{zero}}} \quad (15.3)$$

So the operation is: change b and look at the clarity of the picket-fence pattern until it washes out and the Visibility has become zero and then plug b_{zero} into Equation 15.3 and you've then calculated the opening angle of the two stars...or the opening angle subtended by one star.

This was actually attempted by Eduard Stephan in 1874 using a telescope at the Marseille Observatory with a diameter of $D = 80$ cm. He created a mask with two holes that were separated by $b = 65$ cm. The measurement was very delicate. Of course, one has cut down the amount of light falling on the eyepiece by a lot with only the two holes. Plus the interference pattern was very delicate and jittery. He studied the star Sirius, but he could not make b larger than the 80 cm of his telescope and that was not enough. So he was only able to conclude that Sirius' opening angle was smaller than 0.158 arcseconds (about 4.4×10^{-5} degrees). He could not get the Visibility to become zero (nor did he know of that idea since it was not for nearly 50 years later that Michelson defined it). It took Michelson's engineering and mathematical skills to do the job.

He studied this approach with laboratory experiments at Clark and I describe in some detail what he would have seen using a modern lab experiment in Appendix ???. He confirmed his Visibility measure as a way to measure the distance between two stars and the size of one, big star.

⁶This formula is kind of geeky and comes the zeros of a mathematical function called the Bessel Function of the first kind for order 1.

15.2.4.3 Betelgeuse

When astronomers get up in the morning, I think they make coffee and then go to their computer to see if Betelgeuse exploded yet. This is a mammoth giant star in the constellation Orion, and its fancy name is α Orionis. (α means the brightest star in the constellation, β would be the next brightest, and so on. An old naming system and in Orion, it's not true. The blue supergiant Rigel in Orion's belt is actually brighter. But both Rigel and Betelgeuse vary in brightness over time and when the names were frozen in, Betelgeuse must have been on high alert and Rigel less so, and hence, it's β Orion. I digress.) You can see Betelgeuse with your own eyes if you look at the shoulder above Orion's belt. It's red. And it's bright—the 10th brightest in the sky (poor Rigel is seventh). If you replaced our Sun with Betelgeuse it would engulf all of the planets out to Jupiter. It's expected to go supernovae soon, which will be spectacular and no issue for us since it's 600 light years away. That means if it appears to explode tomorrow, that event actually happened six Earth centuries ago. Actually, come to think of it, astronomers might first check on Betelgeuse and *then* make coffee. This star is a big deal, so to speak.

How big is Betelgeuse in miles? Or kilometers? Michelson went through a number of attempts—at Clark University's 4 inch telescope and the Harvard College Observatory's 15 inch telescope and he failed. At the Lick Observatory's 36 inch telescope in 1891 he managed to measure the diameters of the four Galilean moons of Jupiter and while that received both scientific and public attention, his move to Chicago and the intervening efforts in Paris where he worked on standardizing the meter got in the way. Other matters dominated. World War I happened (and he was back in a Naval uniform). But astrophysics didn't stop!

By the early decades of the 20th century it was apparent from theoretical modeling that stars might different sizes, which was a new idea. WWI got in the way but Michelson started corresponding with **George Ellery Hale** (1868-1938) who was the director of the Mount Wilson Observatory which is about a mile above Pasadena, California. There the new 100 inch (2.54 m) Hooker Telescope was the best in the nation. (It's where Edwin Hubble did his famous experiments that showed that the universe is expanding. And, no. James Dean's *Rebel Without a Cause* was filmed in part at Griffith Observatory, also overlooking Los Angeles.)

The only way to succeed was to make the baseline as long as possible and even the 100 inch telescope was not enough separation, so Michelson invented a scheme. Think about this: a brand new, highly delicate, very expensive, exquisitely fragile telescope was to have a 20 foot (6.1 m) steel beam welded to its aperture to accommodate mirrors at the edges.

Figure 15.14 shows the design: instead of holes in the mask which would be less than the aperture, he cleverly collected light far outside of the telescope's opening and with mirrors directed it to the telescope's main mirror. In essence, he turned

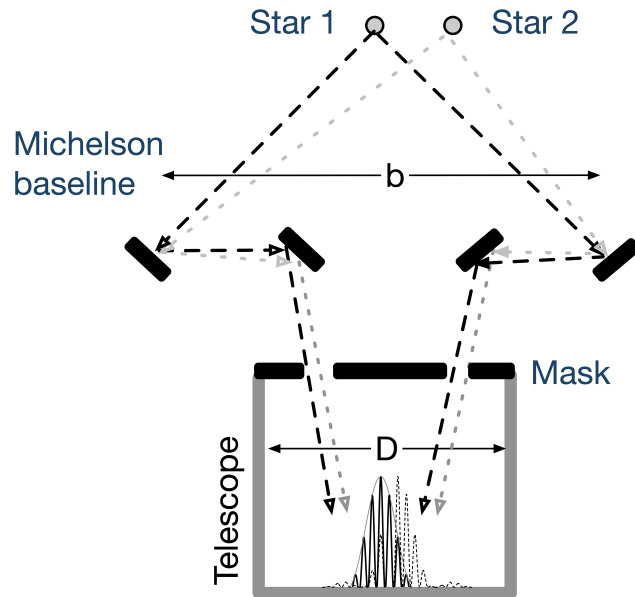

Figure 15.14: The Michelson design to increase the baseline beyond the edges of the Hooker Telescope. $b = 3.07$ m was the sweetspot.

the 2.54 m telescope into a 3.07 m telescope! And that was enough.

He and Frank Pease erected the structure and began measurements on December 13th, 1920. Very quickly, after some calibration, they established the point at which the Visibility became equal to zero while aiming at Betelgeuse. The details are in Appendix ??, but the result is simply stated.

The distance to Betelgeuse was known by them from four observatories' measurements using the "parallax" approach to astronomical distance. Combining the distance to Betelgeuse with their measured opening angle at $b_{\text{zero}} = 3.07$ m which made $V = 0$, that red star's diameter was determined to be 218 million miles or 3.5×10^8 km. A more modern result is 383 million miles. The distance of Jupiter from the Sun is 462 million miles, so that star is solar-system-sized!

Michelson and Pease went on to measure the sizes of six other stars. Michelson's request to expand the beam to 15 meters was denied.

But astronomical interferometry was born and changed astronomy forever.

15.2.5 Interferometers in the Modern Age

The choice of a mask to create the two-hole opening on a single telescope was clever in the 1880s and Michelson's enhancement in the 1920s of the idea to extend the "holes" to sizes that were larger than the telescope itself and that led to new discoveries. But why stop there? His two-mirrored extender-arm was essentially turning the Hooker Telescope into two little telescopes! If we had a telescope of 1

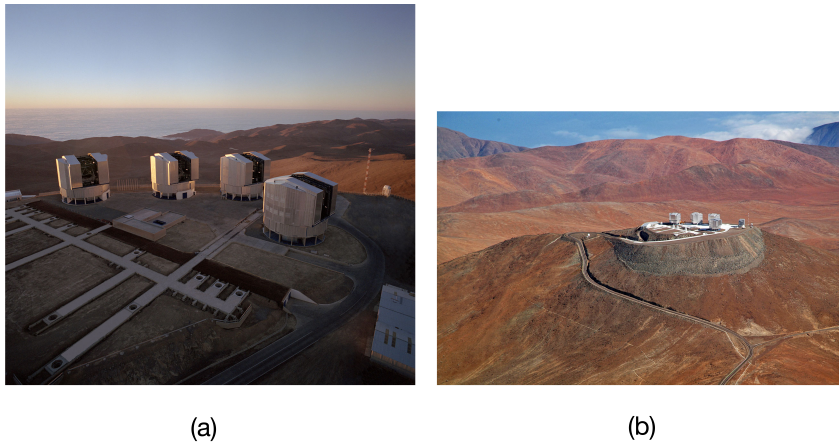

Figure 15.15: In (a) the four fixed main 8.5 m telescopes are shown. In (b) they are clearly visible atop the Cerro Paranal mountain, in the Chilean Atacama Desert. Four auxiliary telescopes are movable and serve as the means by which the baseline can be changed according to the science missions.

meter but captured light at a baseline of 10 meters, sent through a mask, in spite of its puny size, it would have the resolving power of a telescope of 10 meters in aperture.⁷

In 1974, Antoine Labeyrie constructed a two-telescope array at the Nice observatory. The little system consisted of two small telescopes separated by $b = 12$ m. Instead of one image, each telescope created its own, now digital intensity images which were then combined in a single computer system as if they were all one unit. He then published the first such interference fringe measurements in observations of the star Vega and actually asked in the paper if anyone was interested in collaborating on this kind of thing. They were and a new kind of astronomy was born.

In the late 1970's and early 1980's the Mark I, II, and III interferometers operated on Mount Wilson with two telescopes and $b = 32$ m. This was the first modern optical interferometer with many technical innovations that propagated to the present day. From a maximum of a dozen, there are currently fewer than five operating optical/infrared interferometers with the Very Large Array (Figure 15.15) being the largest and with a maximum baselines of $b = 130$ m. *Remember, this means that the optical resolution of VLT is that of a single telescope with a mirror diameter of 130 m!*⁸ Likewise, on Mount Graham in Arizona the Large Binocular Telescope Observatory

⁷The resolving power is much increased, but the amount of light that is captured is considerably reduced. It is a trade-off.

⁸The two 10 m optical telescopes in the W. M. Keck Observatory near the summit of Mauna Kea on the island of Hawaii were originally to be a wide-ranging interferometer. The two telescopes were built, but the auxiliary telescopes, while actually constructed, were never deployed due to sociopolitical disputes about the mountain itself. Interferometry ended at Keck in 2012 when NASA pulled funding for the project. They now operate as superior, but independent optical telescopes.

(LBT) was saw first binocular light in 2008 and operates two 8.4 m telescopes with an effective baseline of $b = 22.8$ m. LBT operates in the near-infrared frequency range where cosmological spacetime expansion would cause distant galaxies to have shifted their radiative wavelengths from the visible to the infrared range.

15.2.5.1 Radio Astronomy

The paradigm jump in astronomy came with the observation of radio wavelength radiation from the cosmos in the 1930's. Radio wavelengths are particularly interesting for a couple of reasons. First, as noted above, the atmosphere passes radio waves through the atmosphere without absorption or distortion. So the entirety of the frequency band called "radio" is accessible on Earth...of course, day and night. For astronomy, these wavelengths extend from centimeters to meters in length. Second, atomic hydrogen is prevalent in every astrophysically interesting objects, from galaxies, to quasars, to neutron stars, to black holes... and in the voids between matter clumps. All of that hydrogen—and the hydrogen in the hydrocarbons and water molecules in your body—was created in the nucleosynthesis after about three minutes following the Big Bang. Atomic hydrogen undergoes a particularly tell-tale emission of radiation with a wavelength of 21 centimeters. Perfect for radio astronomy!

But, remember the Raleigh limit: $\theta_R = 1.22 \frac{\lambda}{b}$, where now λ for radio waves is large...suggesting that resolving objects in the radio range might be impossible! But: with interferometry, the baselines, b 's are huge — the widest distance of an array of radio dishes — making up for the numerator and then-some. In essence, a baseline of an array of small radio telescope dish antennas will have the resolution of a single antenna of that size. We're now talking *kilometers* of baselines.

The most famous radio astronomy observatory in the U.S. is the Very Large Array (VLA) in New Mexico, northwest of Socorro shown in Figure 15.16(a). While the atmosphere doesn't disrupt radio waves...humans do. So radio telescopes must be built in uninhabited regions of the world...and this particular region qualifies as radio-silent. VLA took its first interferometer data in 1976 and the observatory continues to this day as an iconic image of 27 radio dishes, each 82 feet in diameter. They are on railway tracks and are distributed in a Y formation. They are steerable, but of course they ride on the Earth which rotates and so they scan the sky while executing a complicated dance. The VLA baseline is changed throughout a 16 month schedule with the largest being $b = 36,000$ m. It has recently been renamed as "Karl G. Jansky Very Large Array," after Karl Jansky who was the discoverer of astronomical radio waves in 1933.

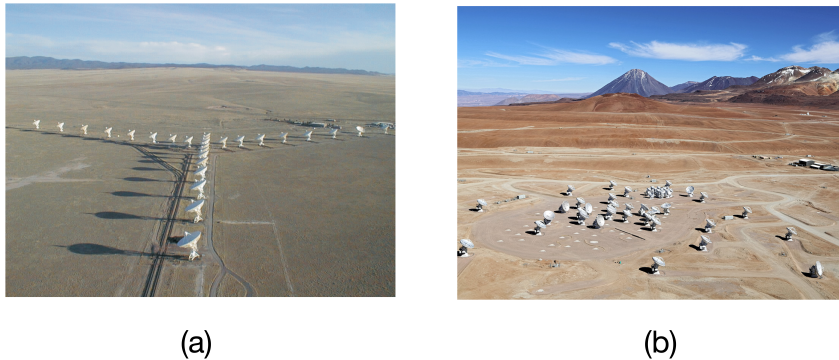

Figure 15.16: Shown in (a) is the VLA array in New Mexico and in (b), the ALMA array in Chile.

There are many other radio telescopes in the world, with the newest and most ambitious being the Atacama Large Millimeter/submillimeter Array (ALMA) operated by the European Southern Observatory shown in Figure 15.16(b). This observatory is in the Chilean Atacama Desert 16,000 feet above sea level and includes 66 precision radio disks of 12 m and 7 m in diameter. They too are movable to a maximum baseline of $b = 16,000$ m across.

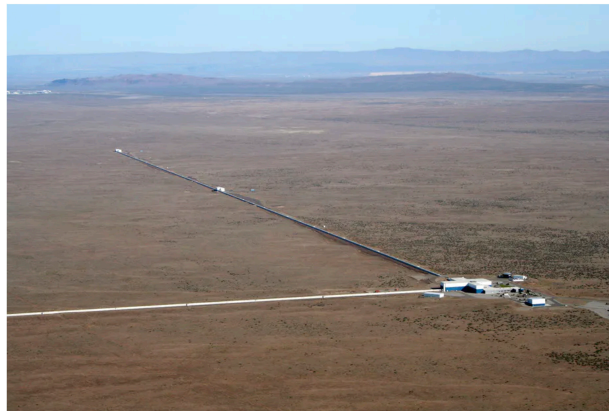

Figure 15.17: The LIGO observatory in Hanford, Washington. Each arm is four kilometers long.

Frankly, the only size limitation for radio astronomy is the size of the Earth. For decades the Very Long Baseline Array (VLBA) has been in operation with 10 radio telescopes from Hawaii to New Hampshire. The effective baseline of the VLBA is $b = 8,600,000$ m and its home is the Pete V. Domenici Science Operations Center at the NRAO in Socorro, New Mexico. Adding in some telescopes in Europe makes it even larger. The processing is formidable and of course the timing to keep them all synchronized is a job for multiple atomic clocks around the world.

Finally, as of this writing: yesterday on May 12, 2022 the Event Horizon Telescope (EHT) collaboration a huge interferometer of 8 radio telescope observatories distributed from the South Pole to Chile, to Spain, to Arizona, to Hawaii announced that they've imaged the black hole at the center of our galaxy. How do you "see" a black hole? When matter is near the "event horizon" of a black hole, which when crossed means that it's never going to escape, it's accelerated around the object at speeds near that of light. These charged particles then emit electromagnetic radiation which is feeble, but detectable on Earth in the radio region.

There is now ample evidence that most if not all galaxies have black holes at their cores and in 2019, EHT imaged such a black hole in the galaxy M87. The Milky Way black hole is more massive than 4 million suns and spins at an enormous rate, visible within a night's viewing. The baseline is huge, spanning three continents, so that reduces θ_R —the denominator. Further, the wavelength probed is in millimeters, a substantial reduction over the centimeter to meter wavelengths of more traditional radio astronomy...again, reducing θ_R even further—the numerator.

Michelson would be astonished and gratified.

15.2.5.2 Gravitational Waves

Perhaps the most ambitious and exotic (but basically classical) Michelson Interferometer, mixed with astronomy is the Laser Interferometer Gravitational-Wave Observatory (LIGO) in two locations, in Livingston, Louisiana and Richland, Washington, on the Hanford federal reservation, shown in Figure 15.17. When massive black holes and neutron stars collide—BH-BH, NS-NS, and BH-NS—the distortion of spacetime is so energetic that it robs the colliding objects of mass (the Einstein T-shirt equation that we'll close this book with) which is converted into gravitational waves, which are literally oscillations in the fabric of spacetime. These waves travel outward from the collision and when they pass through the Earth—literally through the Earth—they cause our planet to slightly shrink and expand. These ripples are tiny. The arms of the Michelson Interferometer are each 4 km long and the shrinkage of one or both of the arms as they shrink with the Earth would be less than 1/1000th of the size of a proton. This is such a delicate measurement, as tiny, tiny vibrations—a car door slamming at outside the cafeteria— could cause a false positive signal. This is far from Michelson stomping on the ground 100 m away from his Potsdam experiment! In order to qualify as a gravitational wave event, simultaneous, identical results must happen at both observatories in two states thousands of miles apart.

The observatory was turned on in 2015 and within two days, the first event was detected and announced in 2016 corresponding exactly with the predictions of Einstein's General Theory of Relativity for the inward spiraling of two colliding black holes of masses of 36 and 29 solar masses, which merged into a single object of a mass of 62 solar masses. The "missing" mass-energy of the original two was

radiated as gravitational waves which were detected on Earth.

Many more collisions and mergers have been observed and a new branch of astronomy created. The 2017 Nobel Prize for Physics was awarded to Rainer Weiss, Kip Thorne and Barry Barish who were responsible for the conception of the experiment and theoretical predictions of what would occur. Expansion of this effort is ongoing with collaboration with a site in India and further upgrading of the two U.S. sites.

Michelson could never have dreamed of his interferometer scaled up to this size, with precision that was beyond his comprehension (since the atom was still not a believable concept in his time), nor scientific concepts still five decades in the future from his first attempts in Potsdam in the 1880s.

15.2.6 The Speed of Light

Michelson's speed of light measurements were deep into a centuries-long effort to determine how fast light travels. He just did it better than anyone else. Historically, these measurements came in roughly three phases as we learned in Chapter ??:

1. Disputes as to whether light travel was instantaneous or finite in time.
2. Astronomical experiments, first to determine whether light has a finite speed, and then to determine it.
3. Terrestrial experiments to determine the speed of light on the Earth.

Michelson's lifelong efforts turned #3 into an experimental physics art-form with unmatched precision. . . until it was matched again and again in the 20th century.

His last experiment was a major undertaking. He determined that the best precision required a long—miles long—tube filled with a gas (he considered hydrogen! Bad idea.) or evacuated of all air. He tried to collaborate with California gas and water companies, but there was no interest. Eventually, given his funding from the Rockefeller Foundation, Carnegie Foundation, and the University of Chicago, he decided to go on his own. After a prototype on an abandoned railroad line he went on the market for a mile-long surface where he would install a pipe about three feet in diameter, welded together, and evacuated of air. James Irvine donated space on his Irvine Ranch and with the Corrugated Pipe Company, he was on his way.

After some delays, in 1930 a 4000 foot-long pipe was installed on the ranch, the optics inserted and commissioned, and air removed. He designed a scheme to bounce the light multiple times within the pipe for an effective distance of 8-10 miles. The strategy was the same as in the past: the Foucault scheme of a rotating mirror, this time a turnstile with 32 facets rotating at 60,000 rpm. Measurements began in February of 1931, but unfortunately, he passed away on May 9, 1931 a few weeks after hosting Albert Einstein at the site.

The experiment was completed by his assistants, Francis Pease (who helped with the Betelgeuse measurement) and Fred Pearson and in 1933 they published their

results after 233 separate measurements showing that the speed was

$$c = 299,744,000 \pm 11,000 \text{ m/s.}$$

On March 10, 1933 an earthquake disturbed the apparatus sufficiently that it was decommissioned and the pipe sold to the County of Orange Highway Department for \$4,687.20.

All in all, Michelson made or set in motion seven ground-breaking measurements of c : 1878, 1879, 1883, 1902, 1924, 1927, and 1933.

The measurement of c has a long history, which we covered in the pre-Michelson chapters. Roughly, the number of attempts are counted in Table 15.1.

Date Range	# Measurements	notable
1676-1849	28	Roemer, 1676
1849-1878	14	Fizeau, 1849
1878-1933	62	Michelson, 1878
1933-1972	37	Michelson, 1933
1972-1978	5	Evenson, 1972

Table 15.1: Five periods of speed of light measurements and the number of experiments performed, and notable examples within each period.

Why only five measurements in the short six year period, and why none after 1978? Well, there's a story there.

15.2.6.1 Modern Measurements, Beyond the Michelson Approach

The approach to this measurement began to evolve, even before Michelson's last two measurements. Recall that the speed of any wave is

$$v = f\lambda$$

where v is the speed of the wave, f is the frequency, and λ is the wavelength. The measurements before 1891 were all time-of-flight experiments, essentially measuring how long it would take for light to go from here to there. But if one could separately determine the frequency of a light source and its wavelength, then the product of the two would also be an indirect measurement of the speed of that light. Already in 1891, **Prosper-René Blondlot** (1849-1930) took Hertz' approach of measuring the wavelength of a spark and using the frequency, calculating the speed from the product. Blondlot did this at the University of Nancy, for both light and radio waves in different bands from 10 and 30 MHz and established that the speeds were the same for the two sources, and that the speed of those radio waves were within a percent of today's value. Note, that this is before Maxwell's field theory was a settled question. That visible light and longer wavelength "light" showed the same speed was an important contribution to the raging "what is Maxwell's Theory" debate in Britain.

Blondlot is unfortunately remembered for a different incident. In 1903 he announced that he had discovered "N-rays" which he insisted was a whole new kind of radiation. This was considered a serious discovery and all over the world, scientists looked for N-rays, but to no avail. In 1905 American Robert Wood visited Blondlot's lab for a demonstration and without his host's being aware, removed an essential piece of his apparatus rendering the results nonsense. But: Blondlot still reported that the experiment was a success and Wood exposed Blondlot to much fanfare. This episode is now in philosophy and history textbooks as an example of how not to do experiments. The consequential humiliation is reported to have caused Blondlot to go insane and hastened his death in 1930.

We saw in Chapter ?? that Weber and Maxwell recognized the speed of light in a particular combination of the electrical (ϵ_0) and magnetic properties (μ_0) of free space, $c = \frac{1}{\sqrt{\epsilon_0\mu_0}}$, so measuring the two parameters would also lead to an indirect determination of c . This was originally done in 1857 by Weber and Kohlrausch and then again in 1907 by Rosa and Dorsey who determined $c = 299,788,000 \pm 30,000$ m/s, which was the leading precision measurement until Michelson's 1926 rotating mirror re-measurement of $c = 299,796,000 \pm 4,000$ m/s.

People had been bouncing radio waves from objects since the 1920's. In 1922 the U.S. Navy was presented with a suggestion that ships could be detected miles away by bouncing radio waves of about $\lambda = 50$ cm and catching their reflections. Knowing the speed of light, the distance could be determined. That went nowhere but when it became apparent that airplanes could be detected long before they were visible, research picked up. Robert Watson-Watt and Arnold Wilkins are given credit for their 1935 work demonstrating 100 mile aircraft warnings might be provided and the "Chain Home" system of two nearly 250 ft high transmitters and two receivers were installed on the south and eastern coasts of Britain. These and other installations were credited with winning the Battle of Britain during WWII. These systems operated at frequencies of 20-30 MHz, and so wavelengths of 15 to 20 meters. This of course was the invention and use of radar.

Louis Essen worked on the radar programs during the war and in the process realized that standing waves could be set up in a metal cavity and their wavelengths precisely determined (by the physical dimensions of the cavity). Their frequencies would be precisely set and so the speed of light might be measured by their product. This he did in 1946 and measured $c = 299,792,000 \pm 3,000$ m/s. There's a story there. This was high compared to the combined optical measurements and Essen took quite a bit of criticism for possible errors. So he redid the experiment—apparently he was a pretty unrepentant, confident guy—in 1950 and measured $c = 299,792,500 \pm 1,000$ m/s. A vindication.

Wavelength determination was becoming the limiting factor in the measurement of c . Here, shorter wavelengths are better determined wavelengths.

In 1958 K. D. Froome used microwave horns at 72 GHz frequencies (corresponding to a wavelength of about 4 mm, so that short wavelength goal was achieved) in a specialized interferometer—so, stepping through peaks and valleys in the interfering waves—to determine that $c = 299,792,000 \pm 100$ m/s. Long gone are visible light measurements of c as the short wavelengths win in precision.

Recall that Michelson was recruited to Paris to help to establish a length standard for the meter and that effort was replicated in 1945 by NIST physicist William Meggers who carefully determined that the wavelength of the green Mercury-198 line was $\lambda = 546.1$ nanometers, so a meter could be defined as a precise number of Mercury wavelengths. Thirteen “Meggers Lamps” were manufactured and distributed around the world so that a global, industrial standardization could be achieved. Mercury lost out to Krypton-86 in 1960 in Germany and the meter was redefined to be the “length equal to 1,650,763.73 wavelengths in vacuum of the radiation corresponding to the transition between the levels $2p^{10}$ and $5d^5$ of the Krypton-86 atom.” That’s where the laser measurement came in.

15.2.6.2 Lasers In The 1960s

Near single-frequency light sources were usually line emissions from atomic transitions, but even the widths of those “emissions lines” were becoming a limit in the precision of light speed experiments. Invention of the laser made it possible to pin down the wavelength more precisely and Kenneth M. Evanson at the U.S. National Institute of Standards and Technology (NIST) pioneered this work by patiently learning to “lock” laser frequencies using a Fabry-Perot interferometer as a part of his tools. The frequency used in his methane-stabilized Helium-Neon laser was 1000 times higher than that of Froome’s radiation and so the wavelength was correspondingly much shorter, leading to a subsequently much more precise determination of λ . It was a complicated experiment but the end result became the end-point of this two century old quest for the speed of light. His result in 1972:

$$c = 299,792,456 \pm 1.1 \text{ m/s.}$$

Notice that this is a 100-fold decrease in the uncertainty, and even that was later reduced six years later by Woods, et al. to

$$c = 299,792,458 \pm 0.2 \text{ m/s!}$$

Much less than a meter per second uncertainty.

15.2.6.3 The End

Speed of light measurements then hit a strange wall. The limiting uncertainty was now not experimental, but the very definition of what a meter is. The speed of light figures into much of fundamental physics, including quantum mechanics: it’s arguably the most fundamental constant in all of nature. And so the quest to determine its speed was turned on its head.

In 1983, the world gave up measuring c ! It's now defined to be

$$c = 299,792,458 \text{ m/s}$$

and the meter is defined to be length of the path traveled by light in a vacuum in $\frac{1}{299,792,458}$ th of a second. So measurements of c are no longer an interesting research problem, but are done in the hallways of every physics department in the world. Using the Michelson interferometer. Now every city will agree on what a meter is.